

8 Joining methods

8.1 Joint methods

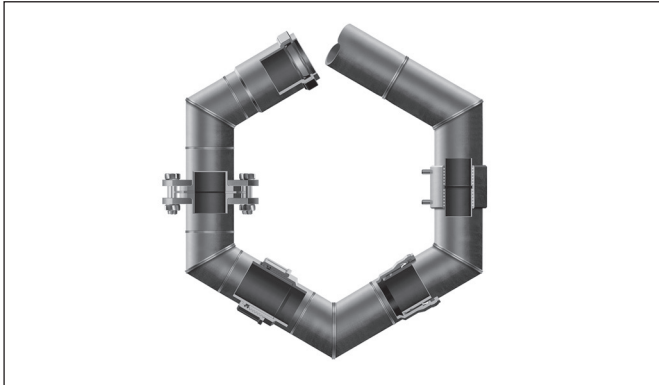

Illustration 8.1

Akatherm HDPE is made of High Density Polyethylene, a material with welded joints. Secure and durable connections lasting 50 to 100 years. Welded joints are made without additional glue or rubber rings joints and are actually the strongest points of the pipe system. HDPE welded joints are both pull tight and leak proof, once tested there is very little risk of future failure because of the flexibility, impact resistance and overall toughness of the material.

Besides welded joints Akatherm HDPE pipes and fittings can be joined by different methods, depending on the application. Joints are divided in welded/mechanical and pull-tight/not pull-tight. Pull tight joints can't come apart under influence of external forces.

Joint method	Welded/mechanical	Pull-tight
Electrofusion	Welded	Yes
Butt-weld	Welded	Yes
Plug-in socket	Mechanical	No
Snap socket	Mechanical	Yes
Screw-thread	Mechanical	No
Screw-thread with bushing	Mechanical	Yes
Flange	Mechanical	Yes
Contraction sleeve	Mechanical	No
Metal Coupling	Mechanical	No

8.2 Butt-weld joint

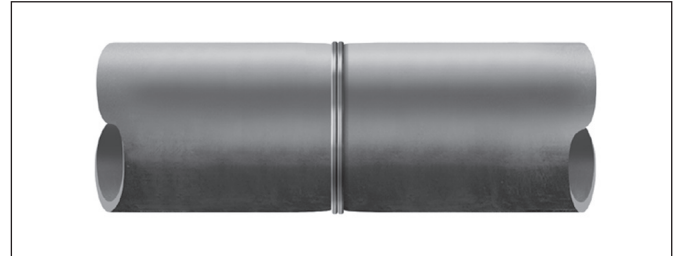

Illustration 8.2

Butt-welding is an economical and reliable way of joining without using additional components requiring only butt-welding equipment.

All Akatherm products can be welded using this joining method. Fittings can be shortened by up to the k-dimension (when indicated in the catalogue), still allowing butt-welding. This joining method is very suitable for prefabrication and producing special fittings.

Preparations

Establish a work space where the jointing can be done without being effected by major weather conditions. The use of wind shields is advised to keep the weld plate at a constant temperature. Temperature -5°C/+40°C.

Without removing the oxygen layer a weld cannot be guaranteed. The oxidation layer will form again within one hour. The butt-weld needs to be made right after machining the ends.

Used surface of heating element for welding diameter d_1	Δt_{tot}
$d_1 = 40-160$	8°C
$d_1 = 200-315$	10°C

Table 8.1 Maximum temperature variation heating element

Joining methods

Welding process

The butt-welding of Akatherm HDPE operates according to the following steps:

Machining the surface

Both sides should be machined until they run parallel. When the machining is finished, open the carriages (the plastic shavings must be continuous and uniform in both sides to weld). Take off the milling cutter.

Verify the alignment between the machined surfaces. Remove the plastic shaving. Do not dirty or touch the machined surfaces.

! Without removing the oxygen layer a weld cannot be guaranteed.

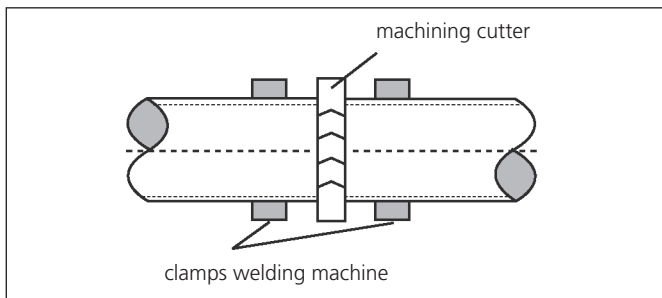

Illustration 8.3 Machining the surface

Preheating under pressure

Press the two ends to be jointed gradually to the heating element until a bead is created. The size of the bead is a good indication that the appropriate pressure and time is used. For pressure and bead size see table 8.2.

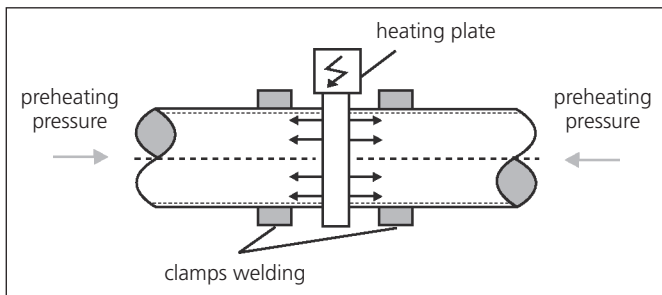

Illustration 8.4 Preheating under pressure

Heating up with less pressure

HDPE is a good insulator, therefore at this stage it is necessary that the correct heating depth of the pipe ends is obtained. Only a small amount of pressure $0,01 \text{ N/mm}^2$ is required to maintain the contact of the ends with the heating element. The heat will gradually spread through the pipe/fitting end. The size of the bead will increase a little. The time and pressure needed for this phase can be found in table 8.2.

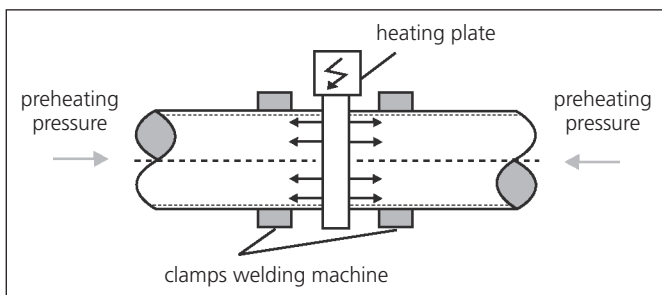

Illustration 8.5 Obtaining the correct heating depth

Change over

Remove the heating element from the jointing areas and immediately join the two ends. Do not push the ends abruptly onto each other.

The removal of the heating element needs to be done quickly to prevent the ends from cooling down. The times for changing over can be found in table 8.2.

Welding and cooling

After the jointing areas have made contact they should be joined with a gradual increase in pressure up to the specified value. The building-up of pressure should be done linear and not differ more than $0,01 \text{ N/mm}^2$. When the buildup occurs too fast the plastic material will be pushed away. When the pressure buildup is too slow the material cools down. In both cases the quality of the weld is questionable. Keep the specified welding pressure at a constant level during the complete cooling period. There must not be any load or strain at the joint. Do not cool artificially.

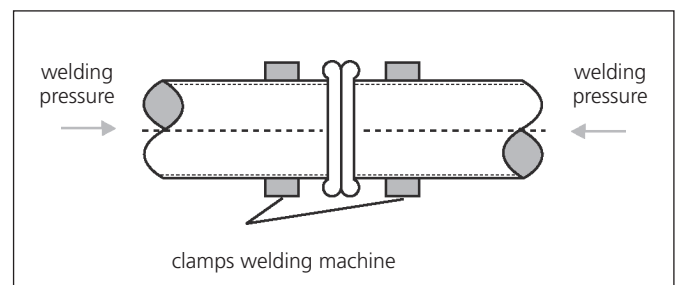
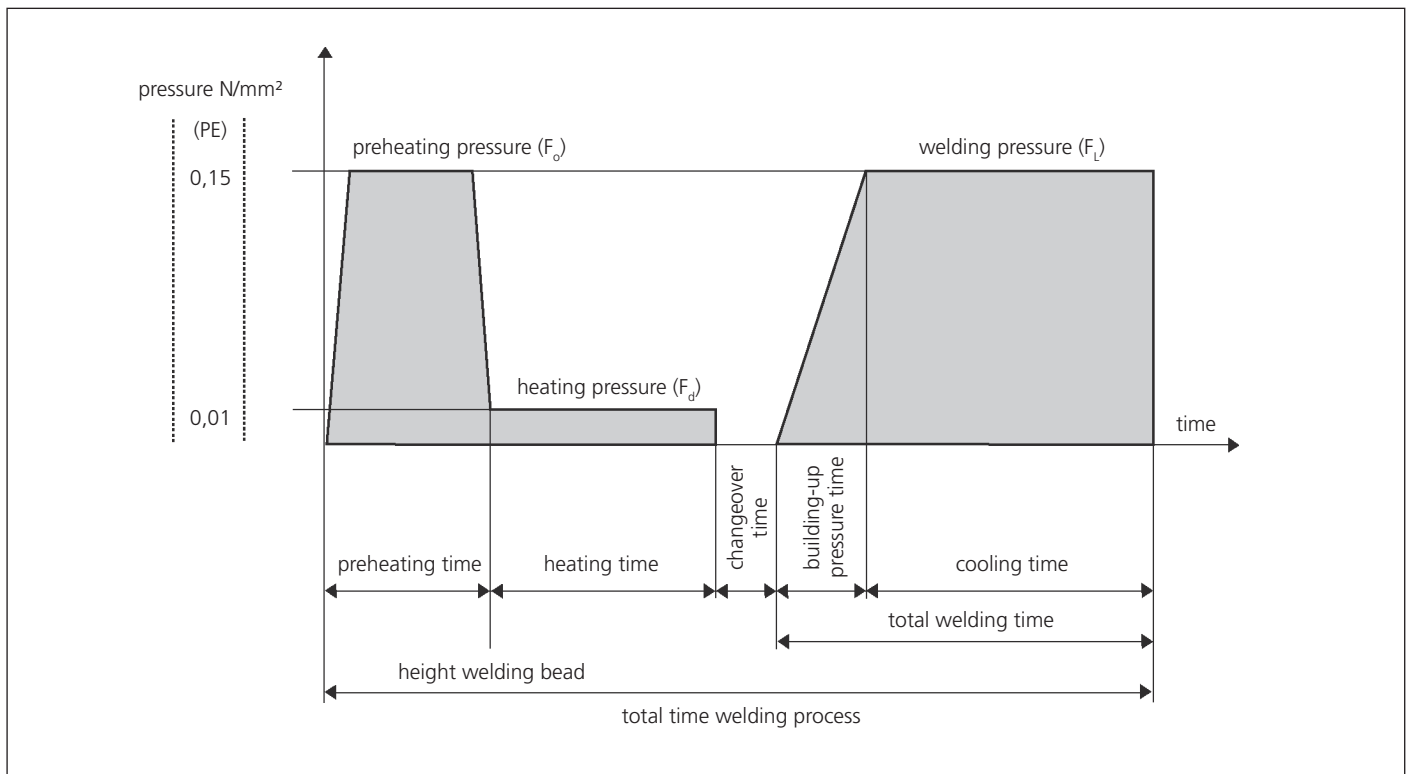

Illustration 8.6 Welding and cooling

The welded components can be removed from the machine when 50% of the cooling period has elapsed, providing that this is done carefully, with no load or strain being placed on the joint. The joint must then be left undisturbed for the remainder of the cooling period.



Graphic drawing 8.1

Diameter	Wall thickness	Preheating pressure/welding pressure (0,15 N/mm ²)	Heating pressure (0,01 N/mm ²)	Height welding bead	Heating time	Changeover time	Building-up pressure time	Cooling time
d_1	e	F_0/F_L	F_d	mm	sec.	sec.	sec.	min.
mm	mm	F_0/F_L	F_d	mm	sec.	sec.	sec.	min.
40	3,0	55	4	0,5	29	4	4	4
50	3,0	70	5	0,5	30	4	4	4
56	3,0	75	5	0,5	30	4	4	4
63	3,0	85	6	0,5	31	4	4	4
75	3,0	105	7	0,5	32	5	5	4
90	3,5	145	10	0,5	35	5	5	4
110	4,2	210	14	0,5	42	5	5	6
125	4,8	275	18	1,0	48	5	5	6
160	6,2	450	30	1,0	62	6	6	9
110	3,4	175	12	0,5	35	5	5	4
125	3,9	225	15	0,5	39	5	5	5
160	4,9	370	25	1,0	49	5	5	7
200	6,2	570	38	1,0	62	6	6	9
250	7,8	900	60	1,5	77	6	6	11
315	9,7	1400	93	1,5	77	6	6	11
200	7,7	700	47	1,5	77	6	6	11
250	9,6	1090	73	1,5	97	7	7	13
315	12,1	1730	115	2,0	121	6	8	16

Table 8.2 Welding parameters Akatherm HDPE drainage

In table 8.2 the welding parameters can be found for Akatherm HDPE. The exact regulation of the welding machine depends on its mechanical resistance. The tables provided with the machine are to be used for regulating the machine.

Jointing methods

Evaluating the butt-weld joint

The butt-weld can be evaluated using destructive and non destructive evaluation methods. For these evaluations special equipment has to be used. Butt-welds can easily be judged by a visual inspection, making this the recommended method for a first evaluation.

The shape of the welding bead is an indication for the proper operation of the welding process. Both welding beads should have the same shape and size. The width of the welding bead should approximately be 0,5 x the height. Differences between the beads can be caused by the difference in HDPE material used in the welded components. Despite the differences in welding bead the butt-weld can be of sufficient strength. In illustration 8.7 a good weld is shown with a uniform welding bead. At a visual inspection this would be classified as an "acceptable" weld.

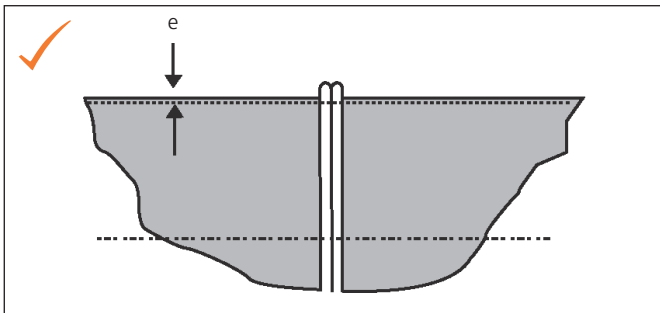

Illustration 8.7 Butt-weld with even welding beads (acceptable)

Mis-alignment between fittings and pipe can occur for several reasons. Oval pipe ends or irregular necking of the pipe can cause an incomplete fit. If this sagging is less than 10% of the wall thickness the weld can still be classified as "acceptable" (see illustration 8.8).

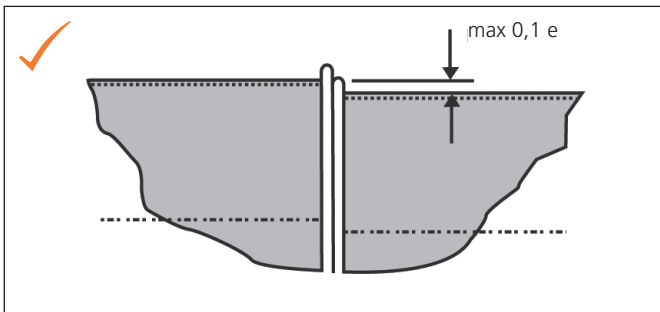

Illustration 8.8 Butt-weld with mis-alignment of pipe (acceptable)

Illustration 8.9 shows a joint with beads that are too big. The uniformity indicates a good joint preparation. However, heat supply and/or jointing pressure seem to be too high. A purely visual assessment would still classify the weld as "acceptable".

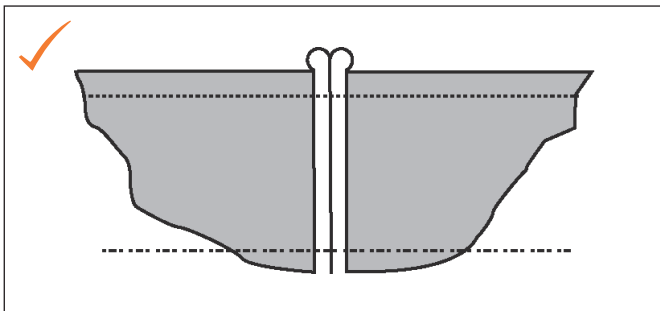

Illustration 8.9 Butt-weld with big welding beads (acceptable)

When there is either insufficient heating up or not enough welding pressure there are hardly any beads. In cases like this thick walled pipes often form shrinking cavities. The weld must be classified as "not acceptable".

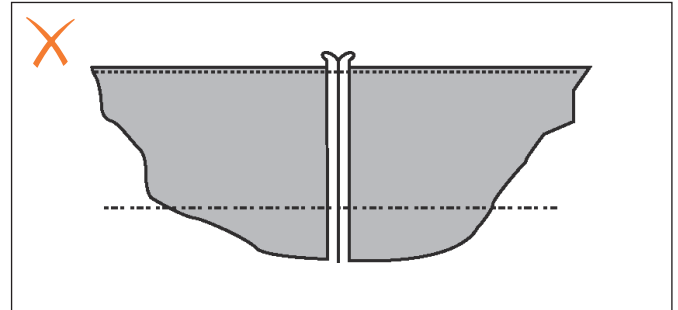

Illustration 8.10 Butt-weld (not acceptable)

In illustration 8.11 a cross-section of a regular, round fusion bead, free of notches or sagging is shown. Special attention should be paid to the fact that the collar value 'K' is greater than 0.

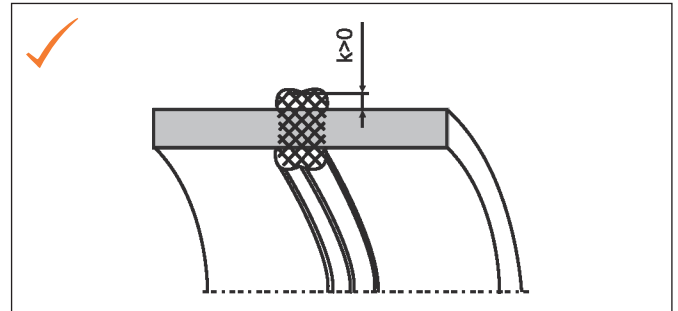

Illustration 8.11 Cross section of a good butt-weld

Welding by hand

In general butt-welds are made using an Akatherm butt-welding machine. However up to the diameter $d_1 = 75$ mm the weld can be made by hand. At 90 mm and above the welding pressures are too big to make a good weld by hand. The welding process is identical to butt-welding with a machine:

Preheating

Push the pipe/fittings against the heating plate until the required welding bead has been formed (for height of welding bead see table 8.2).

Heating up

Hold the pipe/fittings against the heating plate with no pressure (for time see table 8.2).

Change over/welding/cooling

As the spigots are thoroughly heated up both parts need to be joined as quickly as possible using a gently buildup of pressure. The jointing has to be carried out accurately because moving the parts during and after jointing is not possible.

Keep the parts jointed together under pressure as long as the welding bead is still plasticized (this can be checked by pressing your fingernail into the bead). The joint then needs to cool down without any additional load. The use of a support structure is recommended when jointing long pipe parts. Using a butt-welding machine gives a better result under all circumstances.

8.3 Electrofusion joint

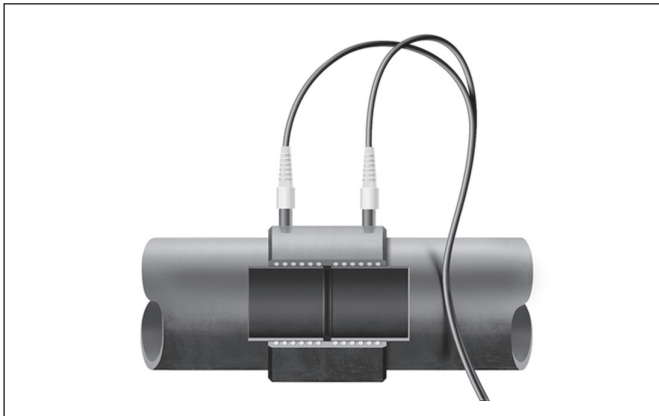

Illustration 8.12

Electrofusion is a rapid and simple way of permanent jointing. Using the electrofusion couplers and equipment, pipes, fittings and prefabricated pipe sections can efficiently be assembled. All Akatherm products can be welded by electrofusion unless specifically stated in the product table.

Preparations

The following guidelines are of importance when making a proper electrofusion joint:

- Establish a work space where the welding can be done without being effected by major weather conditions. Temperature $-10^{\circ}\text{C}/+40^{\circ}\text{C}$.
- Check if the equipment functions properly. Welding equipment used on site deserves special attention.
- The resistance wire in the electrofusion coupler lies at the surface for a good heat exchange. The resistance wires need to be covered by the inserted pipe or fitting to guarantee a proper working.
- Complete insertion is essential to utilize the fusion and cold zones in the coupler.
- Make sure both ends inserted into the coupler have been properly scraped and have been cleaned. Both pipes and fittings need removal of the oxidation layer.

The resistance wires are positioned in the fusion zone. On both sides of a fusion zone, a cold zone prevents the molten HDPE from outpouring thereby containing the fusion process.

During the fusion process the pipe/fitting expands and touches the inner coupler wall. The electrofusion joint is made with the pressure caused by the expanding HDPE and the heat from the resistance wires.

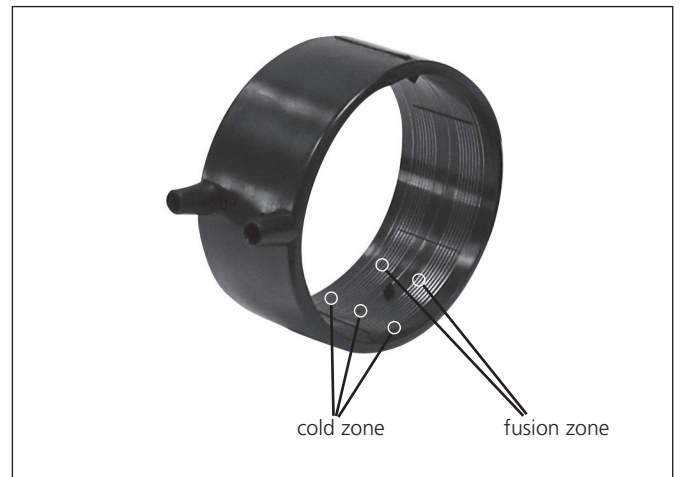

Illustration 8.13 Electrofusion coupler with fusion and cold zones



Warning: Without removing the oxygen layer a weld cannot be guaranteed. The oxidation layer will form again within one hour. The butt-weld needs to be made right after machining the ends.

Joining methods

Welding process

Cut pipe square

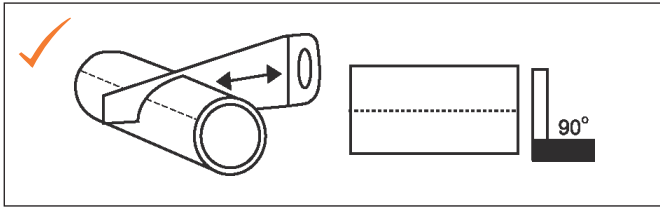

Illustration 8.14

The pipe ends must be cut square to ensure that the resistance wire in the coupler is completely covered by the pipe or fitting.

Mark surface for scraping

Mark insertion depth +10 mm to ensure that across the full welding zone the oxidized layer will be removed.

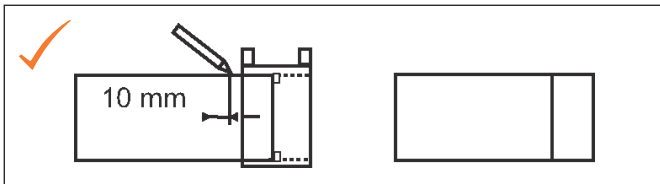

Illustration 8.15

Scrape pipe and mark insertion depth

The full outer surface of the pipe that will be covered by the coupler must be scraped (approx. 0,2 mm deep) to remove any surface 'oxidation'. The insertion depth should be marked again to safeguard full insertion.

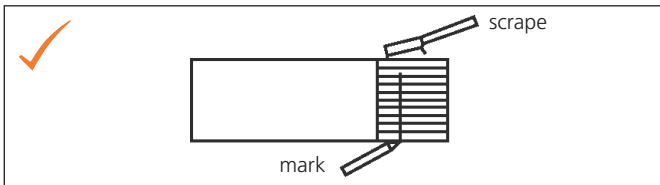

Illustration 8.16

Clean electrofusion coupler

Before assembling the pipes into the coupler ensure that all surfaces are clean and dry.

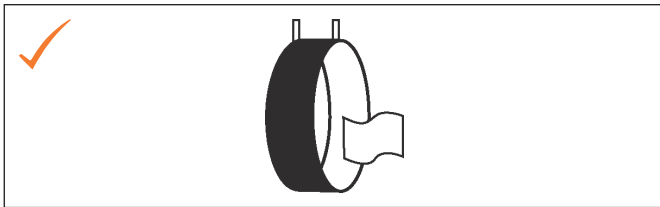

Illustration 8.17

! Insert pipe/fitting until marked line

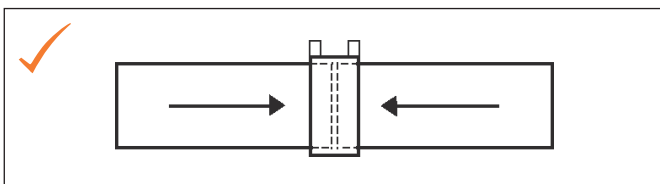

Illustration 8.18

Ensure that the pipe is pushed into the coupler as straight as possible and up to the marked insertion depth. This will ensure that all the wires are covered with HDPE during the fusion cycle.

! Prevent misalignment

Misalignment will cause extra load on the fusion zone causing additional HDPE to melt resulting in the outpouring of HDPE or wire movement.

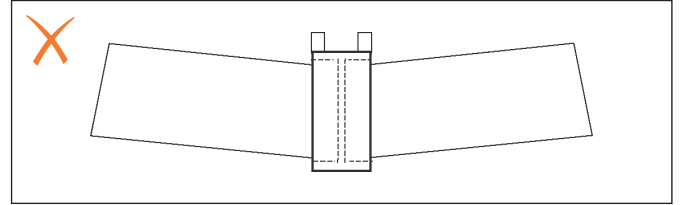

Illustration 8.19

! Prevent joint movement during welding

The movement of the pipe can cause melted HDPE to flow out of the joint. This can result in wire movement and possibly a short circuit and thus a bad weld or fire hazard.

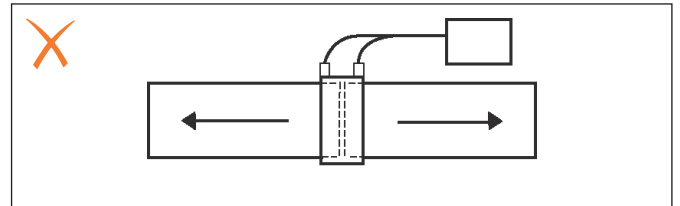

Illustration 8.20

! Prevent coupler from sliding down when center stop removed

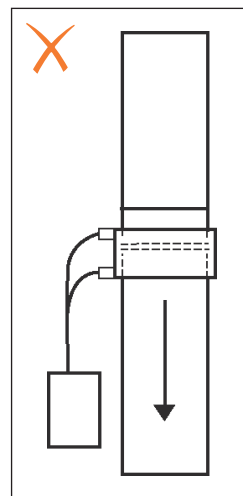

Illustration 8.21

An electrofusion coupler sliding down will cause movement of the wires and possibly a short circuit and thus a bad weld or fire hazard.

! Remove vertical loading during welding

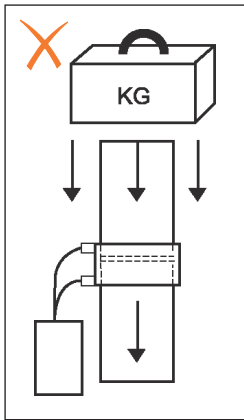

Illustration 8.22

An additional load on the vertical pipe will transfer extra HDPE material to the fusion zone. This will cause movement of the wires and possibly a short circuit and thus a bad weld or fire hazard.

Welding electrofusion coupler and cooling down

After connecting the cables of the control box the fusion process can be commenced by pushing the start button. Both the CB315 and CB160 control boxes adapt the welding time to the ambient temperature. When it is colder than 20°C the welding time is extended and when the ambient temperature exceeds 20°C the welding time is shortened. Welding below an ambient temperature of -10°C is not recommended. For welding times and cooling down times see table 8.3. For extensive instructions see the manual of CB315 and CB160. The joint assembly should not be disturbed during the fusion cycle and for the specified cooling time afterwards.

diameter d ₁ mm	system	welding time sec	cooling time min
40-160	Constant current 5A	80	20
200-315	Constant power 220V	420	30

Table 8.3 Welding parameters electrofusion couplers

The full load can only be applied after the complete cooling time.

The cooling period can be reduced by 50% when there is no additional load or strain during cooling.

! Never weld a coupler twice

During the fusion cycle the right amount of energy is put in to the fusion zones to make a good electrofusion joint. A second fusion cycle would put so much energy into the joint causing the HDPE to melt extensively. This will cause movement of the wires and possibly a short circuit. In the extreme case it can even cause fire.

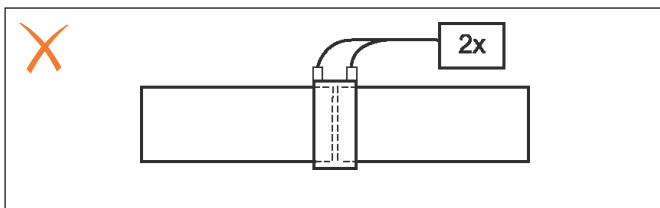

Illustration 8.23

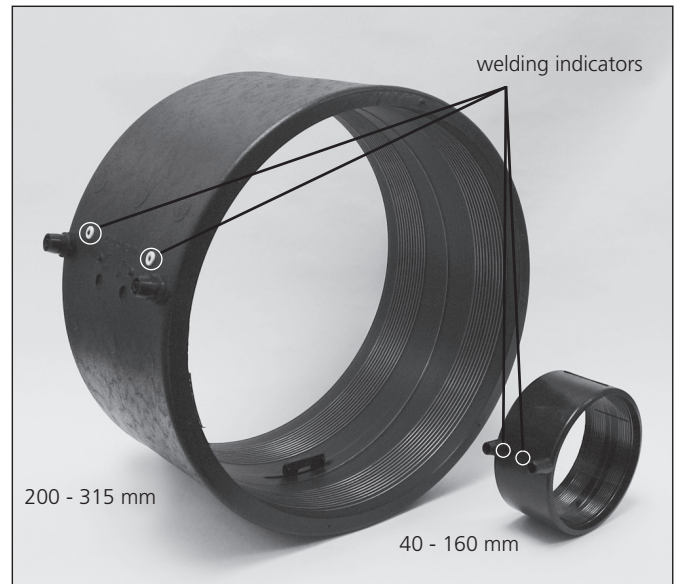

Illustration 8.24

Assessing an electrofusion weld

Compared to a butt-weld, it is harder to judge a good electrofusion weld. The welding indicators on the electrofusion coupler provide an indication if the weld has actually been executed. However, they do not guarantee the integrity of the joint. The amount of movement of the pop-out depends on several factors including the size tolerances of the components and any ovality of the pipe or fitting.

A joint can be marked o.k. when the welding indicators are protuded, all welding preparations such as marking insertion depth, scraping making sure that there was no additional load during welding and cooling have been executed successfully. If a significant quantity of melt flows out from the fitting after welding, there may be a misalignment of the components, the tolerances may be excessive or a second welding may have accidentally occurred. The integrity of such a joint is suspicious.

Please note that the fitting will become too hot to be touched during the welding process. The temperature will continue to increase for some time after the fusion process has been completed.

Deformation

A too big deformation of pipe and fitting can cause problems during assembly and welding of the components. The maximum allowed deformation of pipe or fitting spigot is 0,02 x d₁. This results in a maximum difference between the largest and smallest diameter corresponding with table 8.4. The pipe or fitting spigot needs to be "rounded" using clamps when the deformation is larger.

diameter d ₁	d ₁ max - d ₁ min (mm)
40	1,0
50	1,0
56	1,0
63	1,0
75	1,5
90	2,0
110	2,0
125	2,5
160	3,0
200	4,0
250	5,0
315	6,0

Table 8.4 Deformation pipe

Joining methods

8.4 Plug-in joint

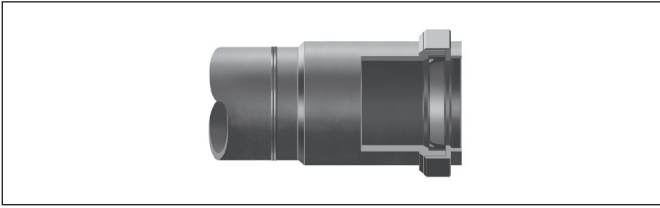

Illustration 8.25

A plug-in joint is an easy to make detachable and not pull-tight joining method.

Joining process:

Cut pipe square and remove burr

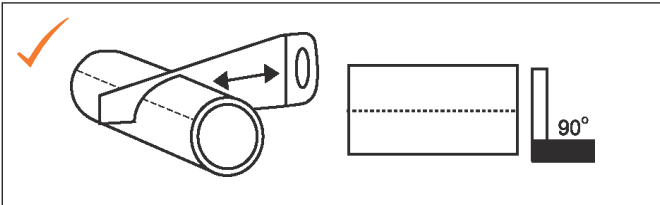
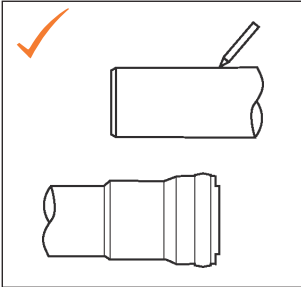

Illustration 8.26

Mark insertion depth



Plug-in socket:

The pipe needs to be inserted in the plug-in socket using the full insertion depth.

A plug-in joint is not to be used to accommodate the expansion and contraction of a pipe system.

Illustration 8.27

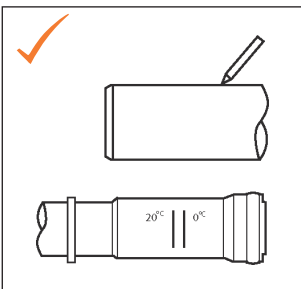

Expansion socket:

A snap-expansion socket is used to accommodate the expansion and contraction in a pipe system.

The insertion depth is marked on the socket for both ambient temperatures of 0°C and 20°C. For detailed information see also paragraph 7.4.

Illustration 8.28

Chamfer pipe end

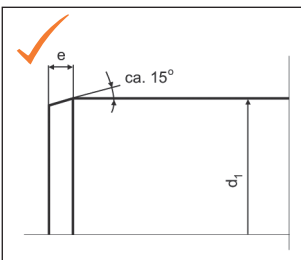

The pipe-end needs to be chamfered under an angle of 15°. A chamfering tool should be used to get an even cut and chamfer.

Illustration 8.29

Make joint

Lubricate the pipe end and insert the pipe up to the marked insertion depth.

8.5 Snap joint

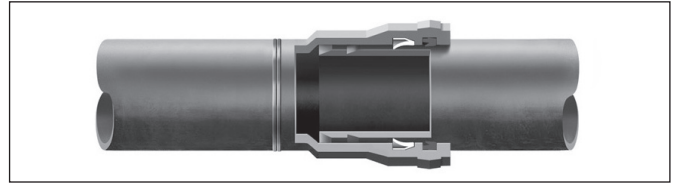

Illustration 8.30

For making pull-tight connections, snap (expansion) sockets are available. These sockets are plug-in sockets with an extra snap ring which provides, in combination with a groove in the pipe, a pull-tight connection.

Joining process:

Cut pipe square and remove burr

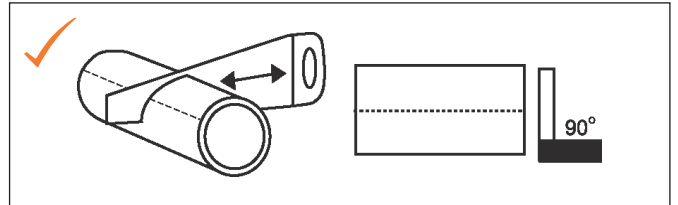
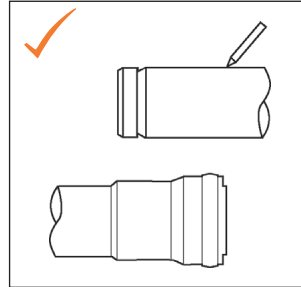

Illustration 8.31

Mark insertion depth



Snap socket:

The pipe needs to be inserted in the snap socket using the full insertion depth.

A snap socket is not to be used to accommodate the expansion and contraction of a pipe system.

Illustration 8.32

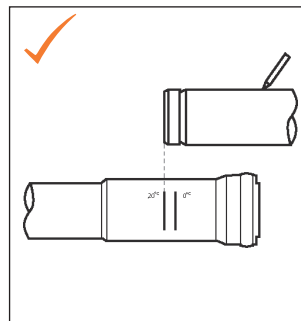

Snap-expansion socket:

Snap-expansion sockets are available from d40 to 75 mm and are used to accommodate the expansion and contraction in a pipe system.

The insertion depth is marked on the socket for both ambient temperatures of 0°C and 20°C. For detailed information see also paragraph 7.4.

Illustration 8.33

Chamfer pipe end and make snap groove

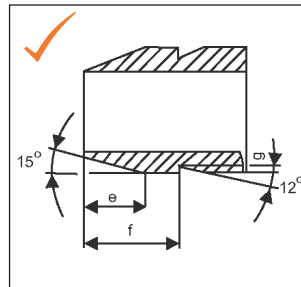

The pipe end needs to be chamfered under an angle of 15°. The groove needs to be cut under an angle of 12°.

The correct dimensions can be found in table 8.5. To get an even cut and chamfer it is recommended to use an Akatherm groove cutter.

Illustration 8.34

d₁	e	f	g
40	5	15	1
50	5	15	1
56	5	15	1
63	5	15	1
75	5	15	1
90	6	15	1
110	8	15	1
125	9	15	1
160	11	15	1
200	11	30	2
250	15	30	2
315	18	50	3

Table 8.5 Dimensions chamfer and groove

Make joint

Lubricate the pipe end and insert the pipe up to the marked insertion depth. A distinguished click can be heard when the snap ring is inserted in the groove.

Remark:

When the groove is not made, the Akatherm snap and snap-expansion sockets are detachable like a not pull-tight joint.

8.6 Screw-threaded joint

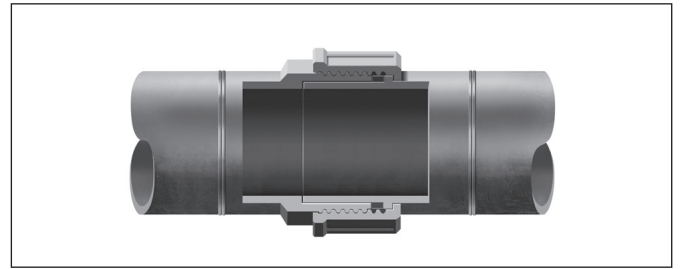

Illustration 8.35

The Akatherm screw threaded joint can be used in both pull-tight and not pull-tight joints.

Not pull-tight joints

In this case the pipe or fitting is inserted directly into the joint.

Joining process:

- **Cut pipe square and remove burr**
- **Disassemble screw threaded joint**
Yellow protection cap is no longer needed.
- **Assemble joint and insert pipe**
Push the nut, washer and seal (in this order) over the pipe and insert the pipe end into the threaded piece completely. Tighten nut.
The washer prevents damage to the seal and delivers an even pressure onto the joint.

Pull-tight joints

In combination with the flange bushing a pull-tight joint can be made.

Joining process:

- **Cut pipe square and remove burr**
- **Disassemble screw threaded joint**
Yellow protection cap and washer are no longer needed.
- **Assemble joint an insert pipe**
Push the nut over the pipe before butt-welding the flange bushing onto the pipe. After welding everything can be assembled.
The flange bushing prevents damage to the seal and delivers an even pressure onto the joint.

Joining methods

8.7 Flange joint

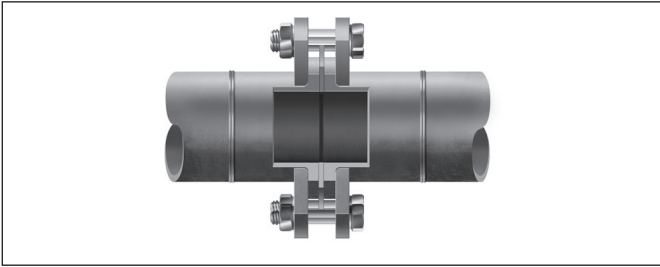

Illustration 8.36

The flanged joint is a detachable joint not that common in soil and waste systems. It is the ideal joining method to connect the system onto flanged equipment and to install valves. The joint can be made by the following steps:

- Mount backing ring over pipe or fitting
- Weld stub flange to fitting or pipe
- Apply seal
- Mount bolts, nuts and washers and tighten nuts crosswise with the bolt torque of table 8.6

d_1 (mm)	Bolt torque (Nm)
40	20
50	30
56	35
63	35
75	40
90	40
110	40
125	40
160	60
200	70
250	80
315	100

Table 8.6 Bolt torque for non-pressure applications

8.8 Contraction sleeve joint



A simple transition to other materials than HDPE can be made using the contraction sleeve. The sleeve provides a not pull-tight connection and is installed as follows:

- Mark insertion depth on the connecting pipe.
- Connect contraction sleeve to HDPE pipe or fitting using electrofusion or butt-welding.
- Mount the O-ring in the middle of the insertion zone.
- Heat up the contraction sleeve evenly with a torch or an industrial heater. Diameters above 125 mm are best heated up using a second heat source.

Illustration 8.37

8.9 Metal coupling

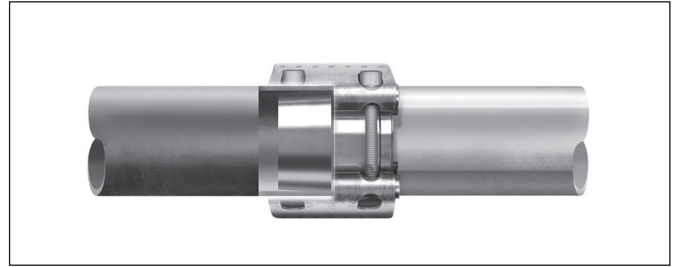

Illustration 8.38

For the transition to another material the standard metal coupler can also be used. Depending on the type, either a pull-tight or not pull-tight joint is possible. To prevent the HDPE pipe from deforming and to disengage from the coupler, a metal support ring should be inserted in the pipe or fitting. The coupling is installed as follows:

- Cut pipe square
- Insert metal support ring into pipe or fitting
- Push connecting pipe ends into coupling
- Tighten nuts with recommended torque

8.10 Pipe-in-pipe joint

A detachable and not pull-tight joint between two pipes with different diameters can easily be made using a rubber collar. A one size collar can be used for several different pipe diameters.

Joining process:

- Cut pipe square
- Place the rubber collar inside the pipe with the largest diameter
- Place the smaller diameter pipe through the collar

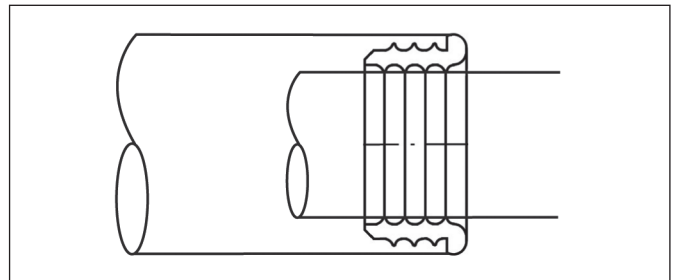

Illustration 8.39